



# DATA SHEET

## T12 Range - up to 12 persons

Suitable for a large house or two houses.



Installation is simple in areas with a high water table - just cover the anchors with 4m<sup>3</sup> concrete.

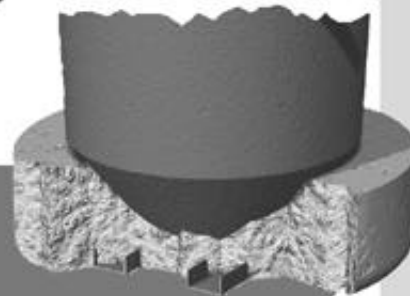

### Why use a



- **Simple process**
  - Quiet operation
- **Simple installation**
  - No concrete back fill required in dry ground
- **Simple maintenance**
  - No moving parts underground

### Environmental Regulations

BIODIGESTER conforms to all the normal '**Consent to Discharge**' environmental requirements of the relevant authorities in the United Kingdom.

### Building Regulations

Building Regulations relevant to a BIODIGESTER sewage treatment plant:

*The Building Regulations 2000 Drainage and Waste Disposal 2002 edition Part H-H2 Package Sewage treatment Works*

### Performance

The plant is designed to produce an effluent quality of:

- BOD 5 20mg/l
- Suspended Solids 30mg/l
- Ammoniacal Nitrogen (as N) 20mg/l

More stringent effluent qualities may also be catered for. The effluent can be discharged to a watercourse or via a soakaway, subject to approval.

**Sewage flow/day 2.4 m<sup>3</sup>**

### What size do I need?

sizing formula (normal residential use):

#### England and Wales:

1 person per bedroom  
+ 0.5 person per house  
(so a 4-bedroomed house would be considered as 4.5 people)

#### Scotland:

1 person per bedspace

## MODEL T12S1 BIODIGESTER

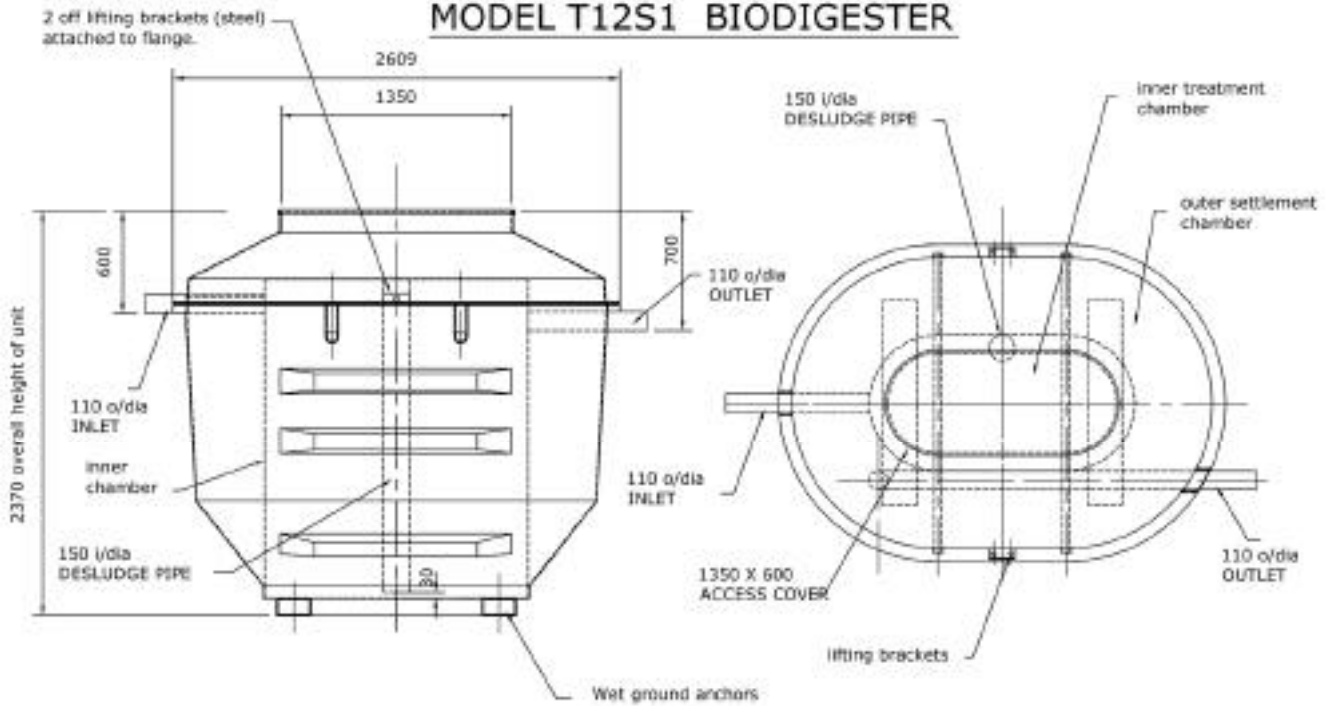

### T<sub>12</sub> References:

T12 standard	inlet drain depth	600mm	ref T12S1
T12 standard	inlet drain depth	900mm	ref T12S2
T12 standard	inlet drain depth	1200mm	ref T12S3
T12 standard	inlet drain depth	1500mm	ref T12S4
T12 integral pumping station	inlet drain depth	600mm	ref T12P1
T12 integral pumping station	inlet drain depth	900mm	ref T12P2
T12 integral pumping station	inlet drain depth	1200mm	ref T12P3
T12 integral pumping station	inlet drain depth	1500mm	ref T12P4

### Dimensions:

#### T<sub>12</sub>S1

**1860 mm** wide  
**2370 mm** deep  
**2610 mm** long  
**600 mm** inlet drain depth  
**weight: 350 kg**

### T<sub>12</sub> Electrical Ratings:

**Air Blower:** 240v 131w Start current 0.76 amps  
**Integral pump:** 240v 150w Start current 2.9 amps

### T<sub>12</sub> Integral Pump Flow:

150 litres/min max head: 5.2m max pipe size 32mm.

To calculate running cost, see

[www.energyfirst.org/runningcosts.htm](http://www.energyfirst.org/runningcosts.htm)

## Extras available for your T<sub>12</sub> BIODIGESTER

### ● SAMPLE CHAMBER

When discharging to a soakaway it is a requirement that you install a sample chamber so that the effluent quality can be periodically checked. Available to suit all outlet depths of our standard range.

### ● HIGH LEVEL ALARM

If you are relying on a pump to discharge the effluent, it is important to install a warning beacon to alert to failure. This is a flashing beacon with a float switch for installing within the pump chamber.

### ● INTEGRAL EFFLUENT PUMP

In areas where you might have a high water table, or not enough space for a soakaway, the treated effluent can be pumped to a suitable point of discharge. The pump is 240 volt, submersible with an integrated float. It is fitted internally.

### ● REMOTE REPORTING

You can be alerted by text to your mobile phone if any problems occur with your unit. Our new remote reporting system is based on mobile phone technology. Contact us for further details.

Once installed, your BIODIGESTER will be virtually invisible.



### BIODIGESTER LIMITED

27 Brightstowe Road  
 Burnham on Sea,  
 Somerset TA8 2HW  
 United Kingdom

**Fax: 01278 793380**

**Email: [sales@biodigester.com](mailto:sales@biodigester.com)**