



DATA SHEET

T18 Range - up to 18 persons

Suitable for 2-4 houses, small hotel/pub.



Why use a

- **Simple process**
 - Quiet operation
- **Simple installation**
 - No concrete back fill required in dry ground
- **Simple maintenance**
 - No moving parts underground

Installation is simple in areas with a high water table - just cover the anchors with 5m³ concrete.

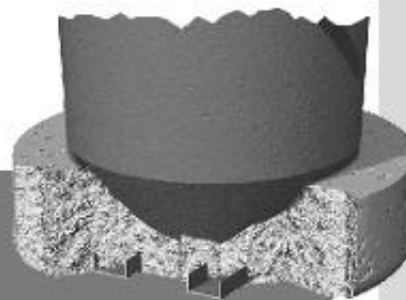

Performance

The plant is designed to produce an effluent quality of:

- BOD 5 20mg/l
- Suspended Solids 30mg/l
- Ammoniacal Nitrogen (as N) 20mg/l

More stringent effluent qualities may also be catered for. The effluent can be discharged to a watercourse or via a soakaway, subject to approval.

Sewage flow/day 3.6 m³

What size do I need?

sizing formula (normal residential use):

England and Wales:

1 person per bedroom
+ 0.5 person per house
(so a 4-bedroomed house would be considered as 4.5 people)

Scotland:

1 person per bedspace

Environmental Regulations

BIODIGESTER conforms to all the normal 'Consent to Discharge' environmental requirements of the relevant authorities in the United Kingdom.

Building Regulations

Building Regulations relevant to a BIODIGESTER sewage treatment plant:

The Building Regulations 2000 Drainage and Waste Disposal 2002 edition Part H-H2 Package Sewage treatment Works

MODEL T18S1 BIODIGESTER

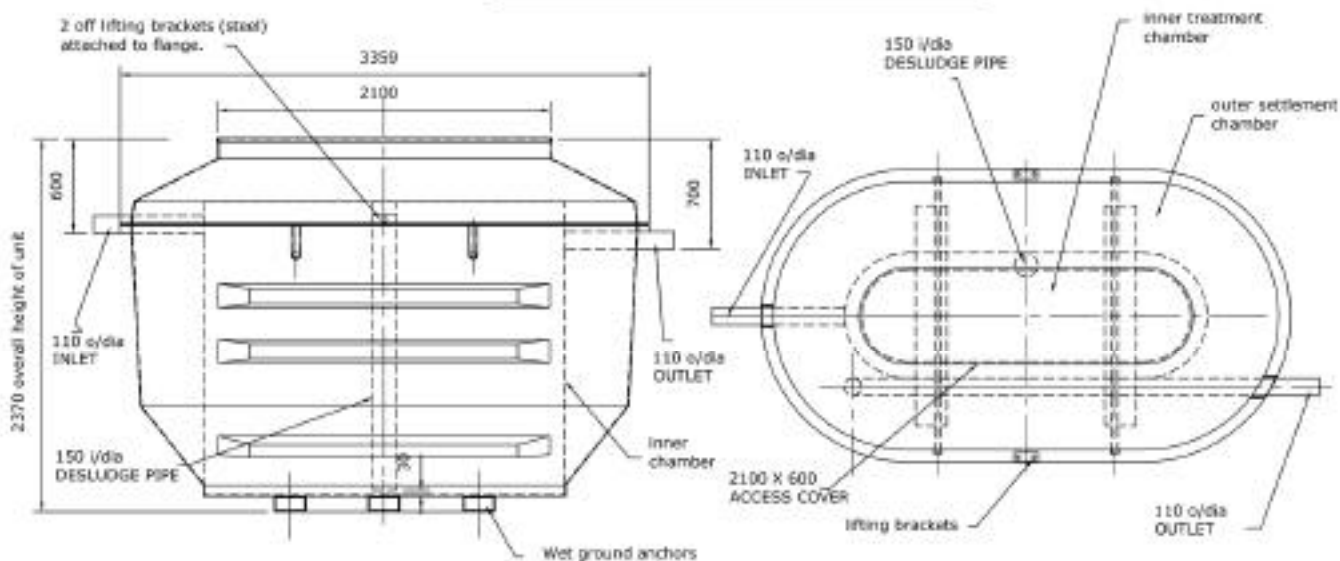

T18 References:

T18 standard	inlet drain depth	600mm	ref T18S1
T18 standard	inlet drain depth	900mm	ref T18S2
T18 standard	inlet drain depth	1200mm	ref T18S3
T18 standard	inlet drain depth	1500mm	ref T18S4
T18 integral pumping station	inlet drain depth	600mm	ref T18P1
T18 integral pumping station	inlet drain depth	900mm	ref T18P2
T18 integral pumping station	inlet drain depth	1200mm	ref T18P3
T18 integral pumping station	inlet drain depth	1500mm	ref T18P4

Dimensions:

T18S1

1860 mm wide
2370 mm deep
3360 mm long
600 mm inlet drain depth
weight: 450 kg

T18 Electrical Ratings:

Air Blower: 240v 237w Start current 1.21 amps
Integral pump: 240v 150w Start current 2.9 amps

T18 Integral Pump Flow:

150 litres/min max head: 5.2m max pipe size 32mm

To calculate running cost, see
www.energyfirst.org/runningcosts.htm

Extras available for your T18 BIODIGESTER

SAMPLE CHAMBER

When discharging to a soakaway it is a requirement that you install a sample chamber so that the effluent quality can be periodically checked. Available to suit all outlet depths of our standard range.

HIGH LEVEL ALARM

If you are relying on a pump to discharge the effluent, it is important to install a warning beacon to alert to failure. This is a flashing beacon with a float switch for installing within the pump chamber.

INTEGRAL EFFLUENT PUMP

In areas where you might have a high water table, or not enough space for a soakaway, the treated effluent can be pumped to a suitable point of discharge. The pump is 240 volt, submersible with an integrated float. It is fitted internally.

REMOTE REPORTING

You can be alerted by text to your mobile phone if any problems occur with your unit. Our new remote reporting system is based on mobile phone technology. Contact us for further details.

Once installed, your BIODIGESTER will be virtually invisible.



BIODIGESTER LIMITED

27 Brightstowe Road
 Burnham on Sea,
 Somerset TA8 2HW
 United Kingdom

Fax: 01278 793380

Email: sales@biodigester.com