



DATA SHEET

T₂₄ Range - up to 24 persons

Suitable for 3-6 houses, small campsite, hotel/pub.



Why use a

- **Simple process**
 - Quiet operation
- **Simple installation**
 - No concrete back fill required in dry ground
- **Simple maintenance**
 - No moving parts underground

Environmental Regulations

BIODIGESTER conforms to all the normal '**Consent to Discharge**' environmental requirements of the relevant authorities in the United Kingdom.

Building Regulations

Building Regulations relevant to a BIODIGESTER sewage treatment plant:

The Building Regulations 2000 Drainage and Waste Disposal 2002 edition Part H-H2 Package Sewage treatment Works

Installation is simple in areas with a high water table - just cover the anchors with 10m³ concrete.

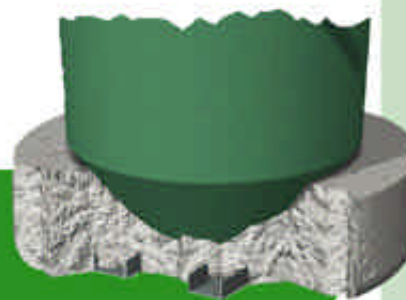

Performance

The plant is designed to produce an effluent quality of:

- BOD 5 20mg/l
- Suspended Solids 30mg/l
- Ammoniacal Nitrogen (as N) 20mg/l

More stringent effluent qualities may also be catered for. The effluent can be discharged to a watercourse or via a soakaway, subject to approval.

Sewage flow/day 4.8 m³

What size do I need?

sizing formula (normal residential use):

England and Wales:

1 person per bedroom
+ 0.5 person per house
(so a 4-bedroomed house would be considered as 4.5 people)

Scotland:

1 person per bedspace

MODEL T24S1 BIODIGESTER

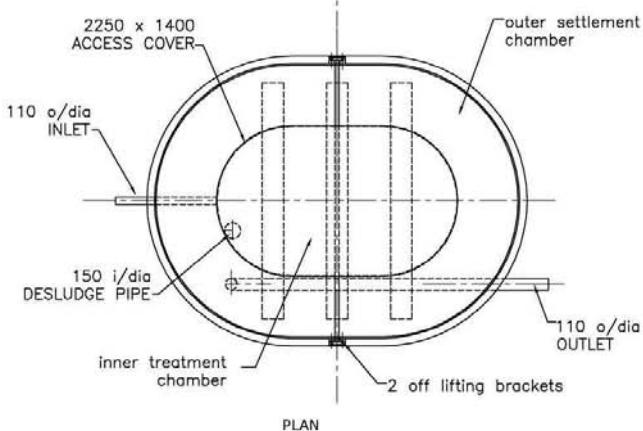
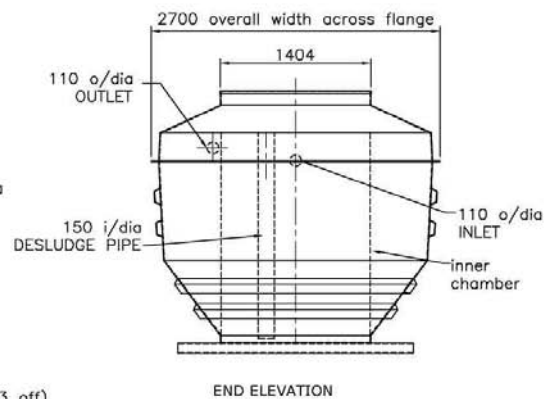
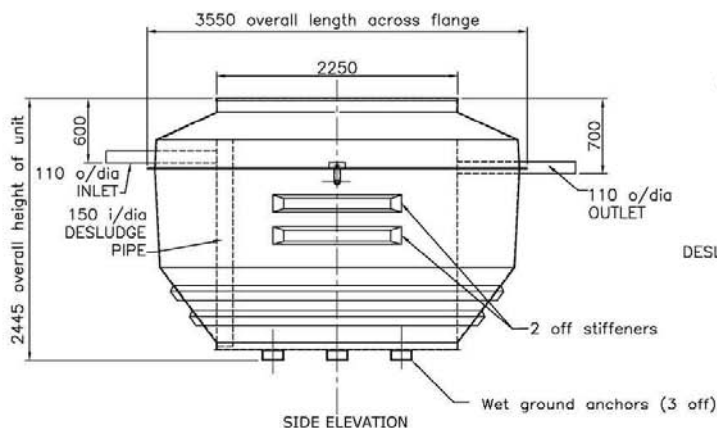

T24 References:

T24 standard	inlet drain depth	600mm	ref T24S1
T24 standard	inlet drain depth	900mm	ref T24S2
T24 standard	inlet drain depth	1200mm	ref T24S3

Dimensions: T24S1

2956 mm wide 2531 mm deep
3656 mm long 600 mm inlet drain depth
weight: 600 kg

T24 Electrical Ratings:

Air Blower:

240v 237 w Start current 1.21 amps

To calculate running cost, see
www.energyfirst.org/runningcosts.htm

Extras available for your T24 BIODIGESTER

● SAMPLE CHAMBER

When discharging to a soakaway it is a requirement that you install a sample chamber so that the effluent quality can be periodically checked. Available to suit all outlet depths of our standard range.

● HIGH LEVEL ALARM

If you are relying on a pump to discharge the effluent, it is important to install a warning beacon to alert to failure. This is a flashing beacon with a float switch for installing within the pump chamber.

● PUMP

Should you require a method of pumping to or from your BIODIGESTER, we have a range of suitable systems to meet your requirements.

● REMOTE REPORTING

You can be alerted by text to your mobile phone if any problems occur with your unit. Our new remote reporting system is based on mobile phone technology. Contact us for further details.

Once installed, your BIODIGESTER will be virtually invisible.



Burnham Environmental Svcs. Ltd.

27 Brightstowe Road
 Burnham on Sea,
 Somerset TA8 2HW
 United Kingdom

Fax: 01278 793380

Email: sales@biodigester.com