



DATA SHEET

T₃₆ Range - up to 36 persons

Suitable for 6-9 houses, campsite, hotel/pub/restaurant.



Why use a

- **Simple process**
 - Quiet operation
- **Simple installation**
 - No concrete back fill required in dry ground
- **Simple maintenance**
 - No moving parts underground

Installation is simple in areas with a high water table - just cover the anchors with 15m³ concrete.

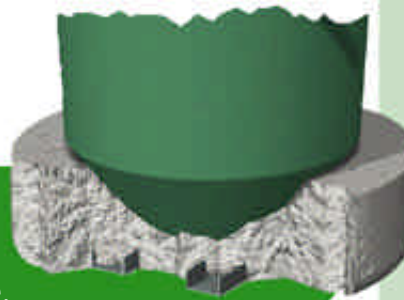

Environmental Regulations

BIODIGESTER conforms to all the normal 'Consent to Discharge' environmental requirements of the relevant authorities in the United Kingdom.

Building Regulations

Building Regulations relevant to a BIODIGESTER sewage treatment plant:

The Building Regulations 2000 Drainage and Waste Disposal 2002 edition Part H-H2 Package Sewage treatment Works

Performance

The plant is designed to produce an effluent quality of:

- BOD 5 20mg/l
- Suspended Solids 30mg/l
- Ammoniacal Nitrogen (as N) 20mg/l

More stringent effluent qualities may also be catered for. The effluent can be discharged to a watercourse or via a soakaway, subject to approval.

Sewage flow/day 7.2 m³

What size do I need?

sizing formula (normal residential use):

England and Wales:
1 person per bedroom
+ 0.5 person per house
(so a 4-bedroomed house would be considered as 4.5 people)

Scotland:
1 person per bedspace

MODEL T36S1 BIODIGESTER

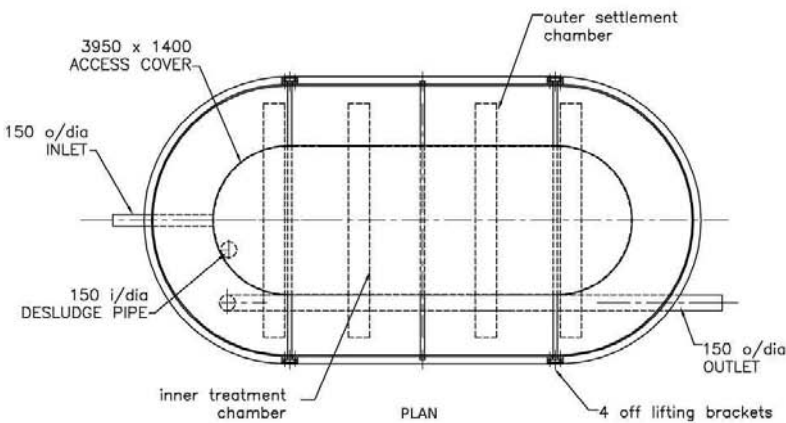
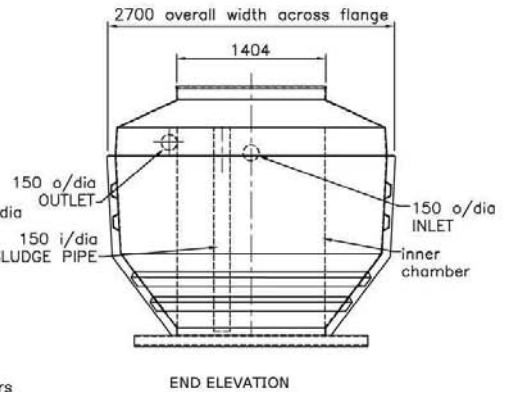
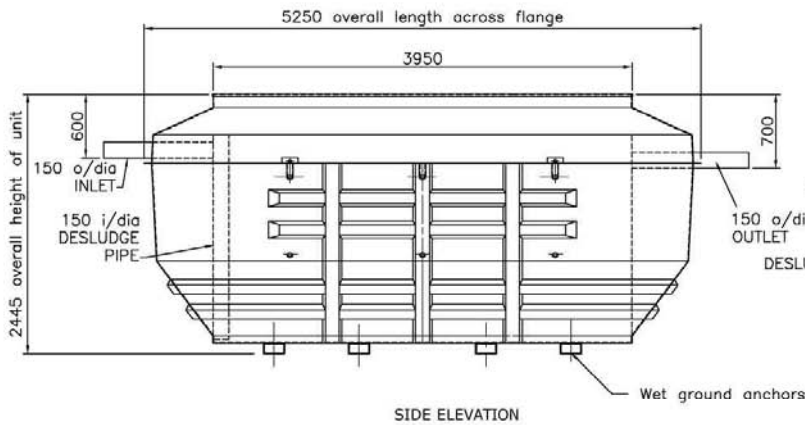

T36 References:

T36 standard	inlet drain depth	600mm	ref T36S1
T36 standard	inlet drain depth	900mm	ref T36S2
T36 standard	inlet drain depth	1200mm	ref T36S3

Dimensions: T36S1

2956 mm wide 2531 mm deep
5056 mm long 600 mm inlet drain depth
weight: 850 kg

T36 Electrical Ratings:

Air Blowers: 1 at	240v	131 w	Start current 0.76 amps
1 at	240v	237 w	Start current 1.21 amps

To calculate running cost, see

www.energyfirst.org/runningcosts.htm

Extras available for your T36 BIODIGESTER

- SAMPLE CHAMBER**
 When discharging to a soakaway it is a requirement that you install a sample chamber so that the effluent quality can be periodically checked. Available to suit all outlet depths of our standard range.
- HIGH LEVEL ALARM**
 If you are relying on a pump to discharge the effluent, it is important to install a warning beacon to alert to failure. This is a flashing beacon with a float switch for installing within the pump chamber.
- PUMP**
 Should you require a method of pumping to or from your BIODIGESTER, we have a range of suitable systems to meet your requirements.
- REMOTE REPORTING**
 You can be alerted by text to your mobile phone if any problems occur with your unit. Our new remote reporting system is based on mobile phone technology. Contact us for further details.

Once installed, your BIODIGESTER will be virtually invisible.



Burnham Environmental Svcs. Ltd.

27 Brightstowe Road
 Burnham on Sea,
 Somerset TA8 2HW
 United Kingdom

Fax: 01278 793380

Email: sales@biodigester.com